

ARLISS 2005 RESULT

JAXA/BLUE COLLARS

Shinji MITANI

Tatsuya ENDO

Daisuke JODOI

Yohei SATO



Our Can-Sat mission and characteristics



- Can-Sat name is “TAMIO-IV”
 - TAMIO aims to surely come back system
- Can-Sat characteristics
 - Cruises by Para foil
 - Very simple configuration
 - Lessons & Learned from last year result are fully reflected

System Configuration

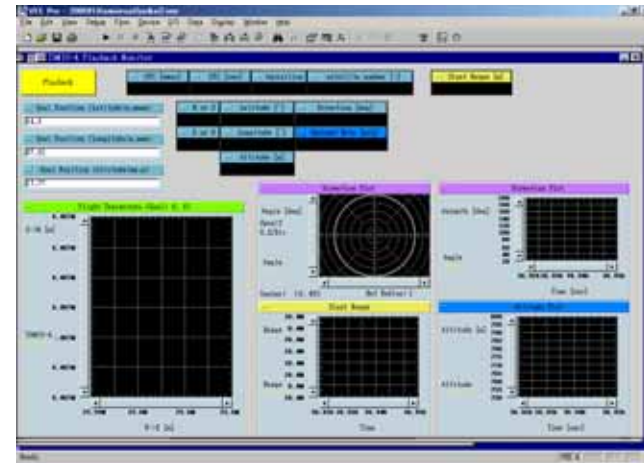
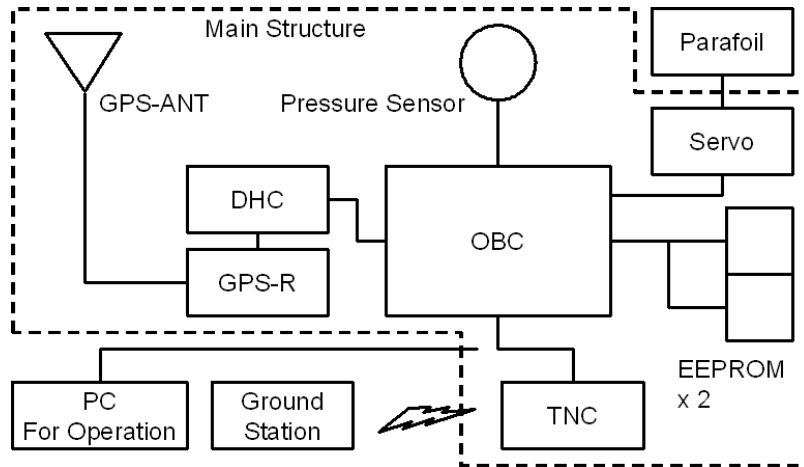

- Very simple configuration
 - Minimum and reliable component
 - (Pressure sensor is installed for future precise control)
- Simple command interface
- Proportional control
- Ground station has GUI

Para foil cruising system



- Designed for reliable deployment
 - Smooth body interface
 - Alleviates rocket fairing friction
 - Snag free folding riser
 - Two-step deployment system
 - Unfold riser first
 - Deploy canopy subsequently



Structure Flame



- Designed for mitigating the shock of deployment
 - Servo horn thick double
 - Shock is dispersed to main structure
 - Programmed as servo torque is zero at deployment

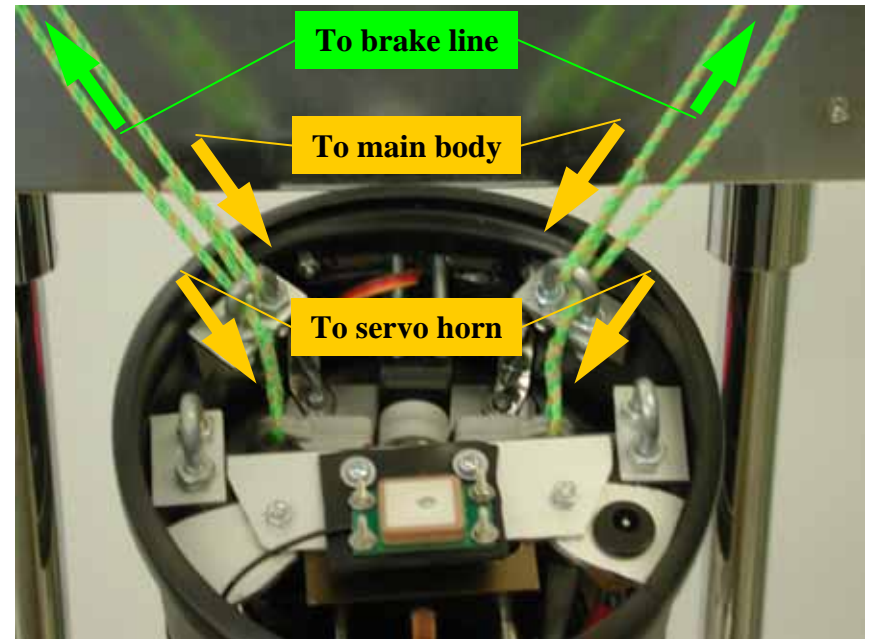

(Broken servo horn,
Last year)

ARLISS result



- Come-back competition result
 - 1340m
 - (Canceled by storm)
- Function works very well
 - GPS and Pressure sensor
 - Control signal and actuate
 - Downlink telemetry



Flight path and control history



- Control signal is correct
- Can-Sat looks turn left correctly according to left signal

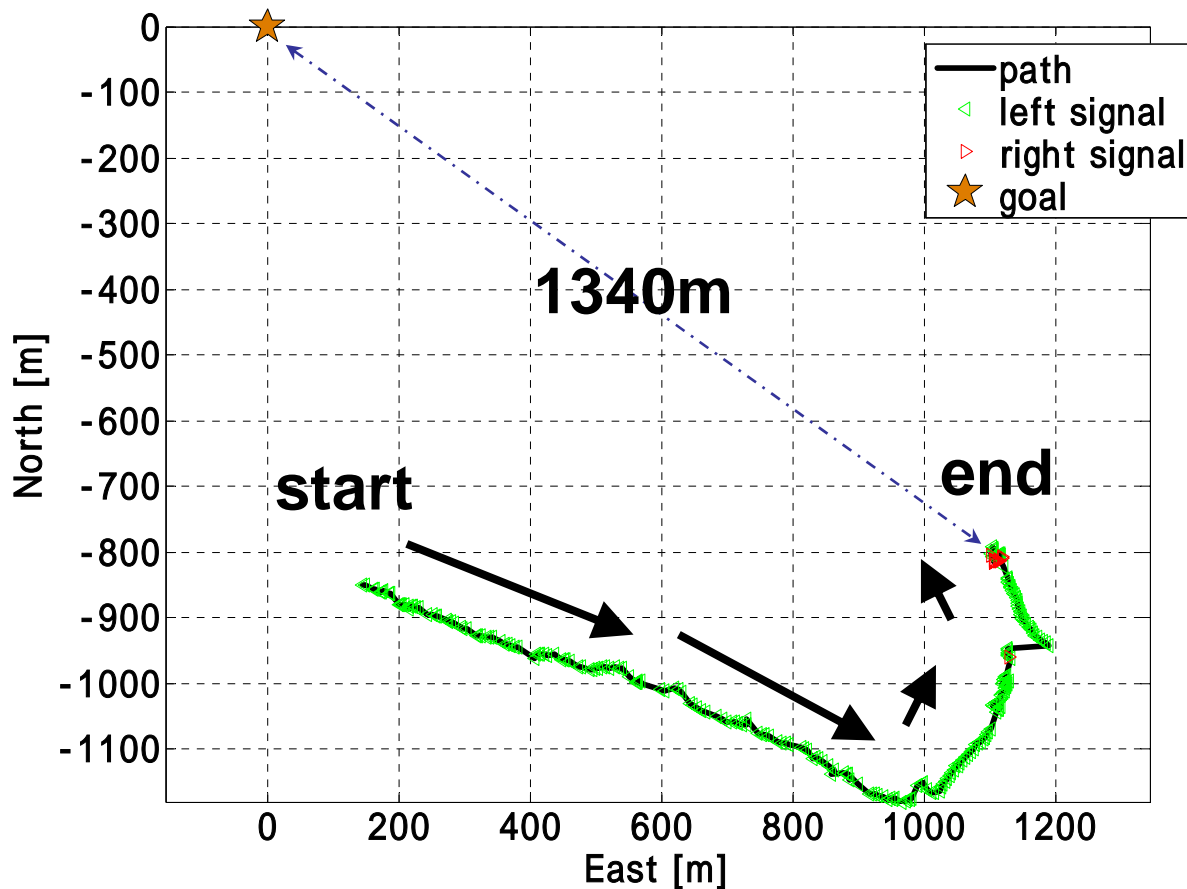

How is can-sat status on flight ? (Estimation)



- Lock on sat number is unstable, so can-sat is on unstable mode
- Para foil is crushed by strong wind, cruised on incomplete status

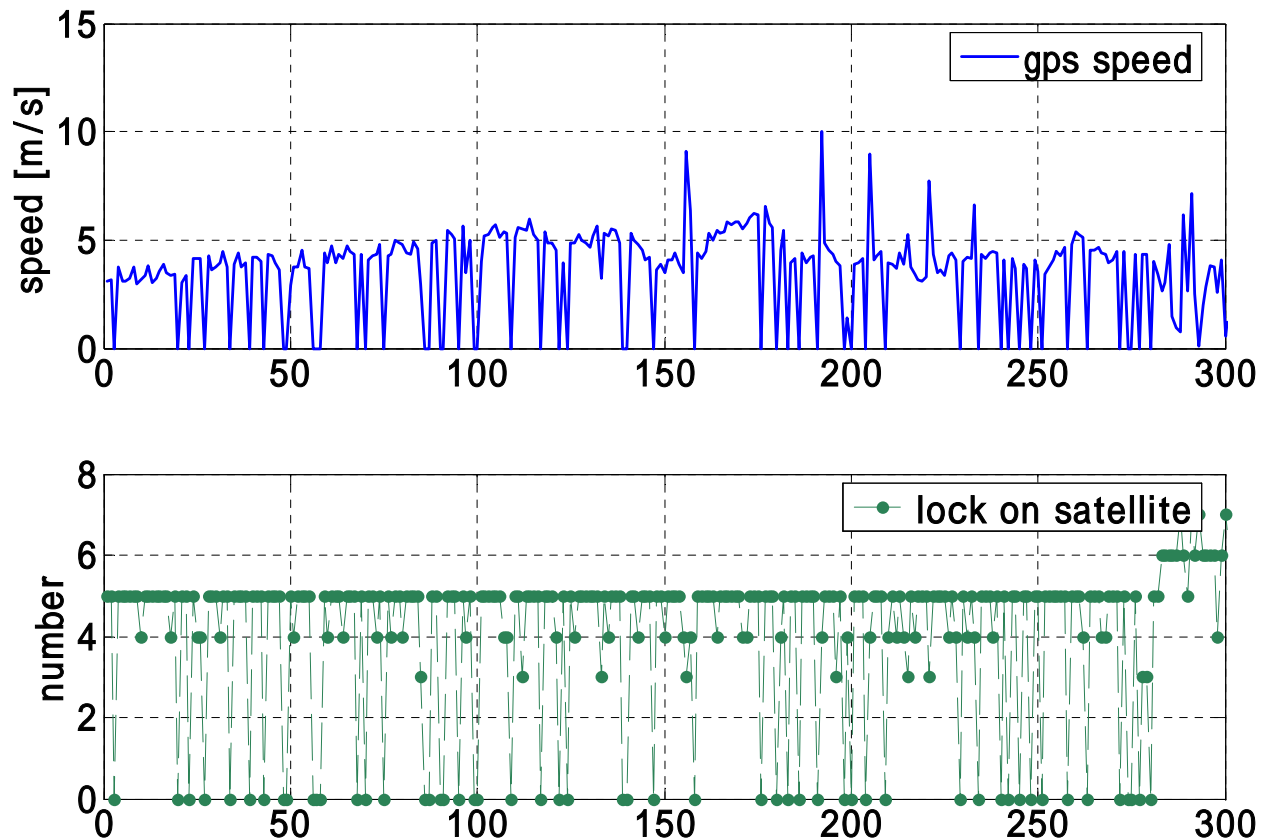

Sensor altitude data



- GPS sensor may use lag smoothed filter in the black box
- Pressure sensor looks correct, so needed for the future precise control

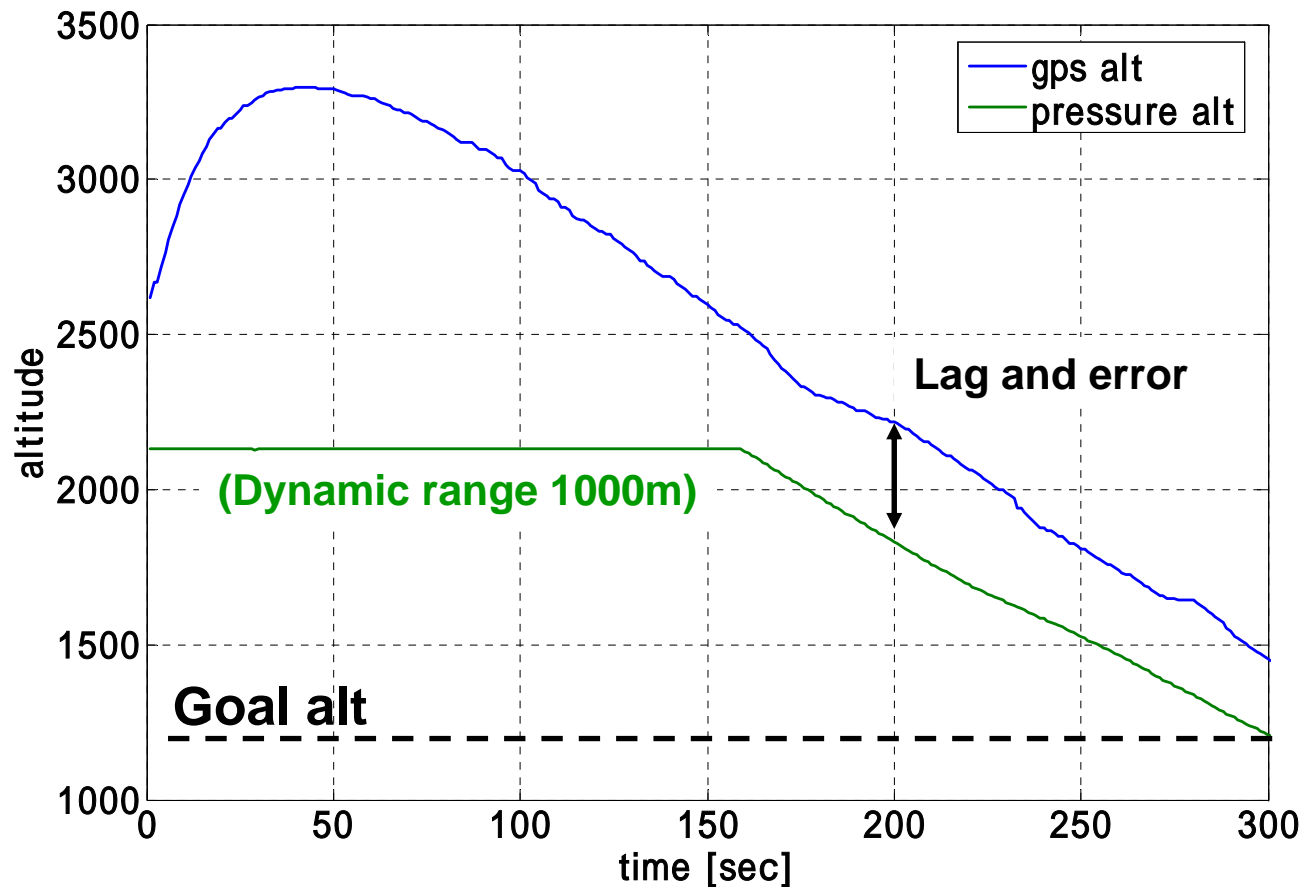

Problem and assignment



- Para foil cruising type is so difficult
 - Certain deployment from tumbled rocket fairing
 - Poor deployment test using real model rocket
 - Very weak for strong wind($> 3m$)
- Assignment
 - Analysis of rocket fairing dynamics at separation more precisely
 - Many deployment test at different status
 - New system which deploy Para foil at low altitude



Our Team Belief



- Made by hand OURSELVES
- SYSTEM Engineering & Management
- Lesson and Learned from EXPERIENCE

Experiences from this program contribute to more reliable and sophisticated spacecrafts, we believe!

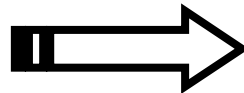
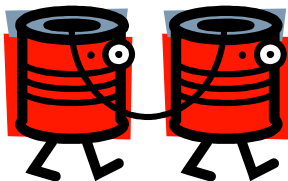

*This is the end of slide, thank you very much